

Rock Master™ Half Round Trailer



Standard Trailer Specifications*

Dimensions	32' Length x 102" Width x 48" Side Height
Lighting	Standard LED Lighting
King Pin/Coupler Height	18" / 49"
Color	White, Black or Gray
Hoist	8", 5 Stage, Inverted Trunnion Mount
Tub	1/4" AR 450 Wear Plate
Nose & Gate	3/16" AR 450 Wear Plate

Axles	25,000 lb. 5" Tubular , 5/8" Wall
Suspension	50,000 lb. Single Point. Keeps 8 Tires on the Ground
Tires/Wheels	11R x 24.5 16 Ply Radials / 10 Hole Hub Piloted Steel
Fenders	Rear Aluminum Bolt-On
Ladders	Front and Rear
Paint	High-Gloss, Reverse-Impact, UV-Protectant, Rust-Inhibiting
Tailgate	Air-Operated Hi-Lift, Integrated Mud Flaps

**Standard features or specifications are subject to change without notice.*

Details



Bolt-On Aluminum Fenders
Allows easy replacement and reduces weight.



Air-Operated Hi-Lift Tailgate
Allows easy flow of material without obstruction.

**CONSTRUCTION
TRAILER
SPECIALISTS**

Half Round Line Drawing

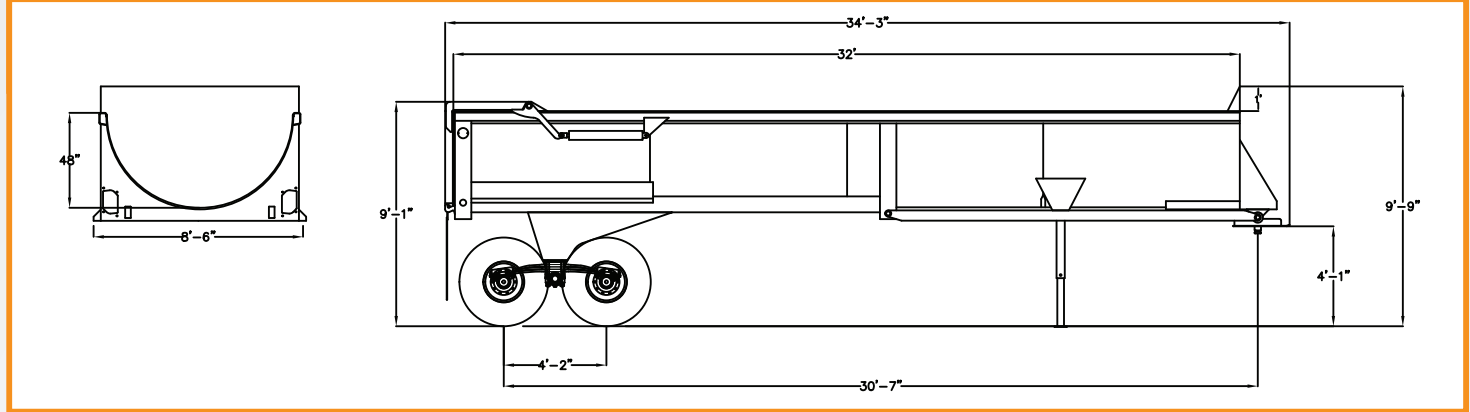

Half Round Volume Capacity

	48"		54"		60"		Dump Angle (±3%)
	Cubic yd.	Weight (±3%)	Cubic yd.	Weight (±3%)	Cubic yd.	Weight (±3%)	
24'	19.850	12,750	23.202	13,100	26.554	13,600	43
28'	23.158	13,600	27.069	14,000	30.979	14,350	45
32'	26.467	14,500	30.936	14,950	35.405	15,350	45
36'	29.775	15,200	34.803	15,700	39.831	16,150	44

Standard Half Round

**ALL 8 TIRES
STAY ON THE
GROUND!**

Options

- » Air Ride Suspension
- » Triple Axles
- » Front & Rear Lift Axle
- » Quarter Frame
- » Full Frame
- » Asphalt Aprons
- » Front Fenders
- » Numerous Tarps
- » Safety Locks
- » Custom Colors
- » Custom Lengths, Side Heights
- » Spreader Chains
- » Numerous Wheels & Tires
- » Cab Kit
- » Tire Carrier
- » Double Hinge Tailgate

For more information, please visit our website at constructiontrailerspecialists.com or call us toll free at 888-669-0003.