

Scrap Master™ Elliptical End Dump Trailer



Standard Trailer Specifications*

Dimensions	40' Length x 102" Width x 76" Side Height
Lighting	Standard LED Lighting
King Pin/Coupler Ht.	18" / 49"
Color	White, Black or Gray
Body	1/4" AR 450 Wear Plate
Nose & Gate	3/16" AR 450 Wear Plate
Tail Gate	Barn Door with Cam Over Center Air Operated Bottom Latch and Ratchet Operated Side Latch

Axles	25,000 lb. 5" Tubular, 5/8" Wall
Suspension	50,000 lb. Single Point
Tires/Wheels	11R x 24.5 16 Ply Radials / 10 Hole Hub Piloted Steel
Paint	High-Gloss, Reverse-Impact, UV-Protectant, Rust-Inhibiting
Draft Arms	5" x 3" x 1/4" Steel Tubes with 2-Speed Landing Gear
Fenders	Rear Aluminum Bolt-On
Capacity (40' L)	64.867 Cubic Yards (76" Side Height) 86.844 Cubic Yards (100" Side Height)

**Standard features or specifications are subject to change without notice.*

Details



Ratchet-Operated Side Latch Allows for easy opening and closing operation.



Rotating Rear Mud Flap Ensures the door is not bent during dump cycle.

Elliptical End Dump Line Drawing

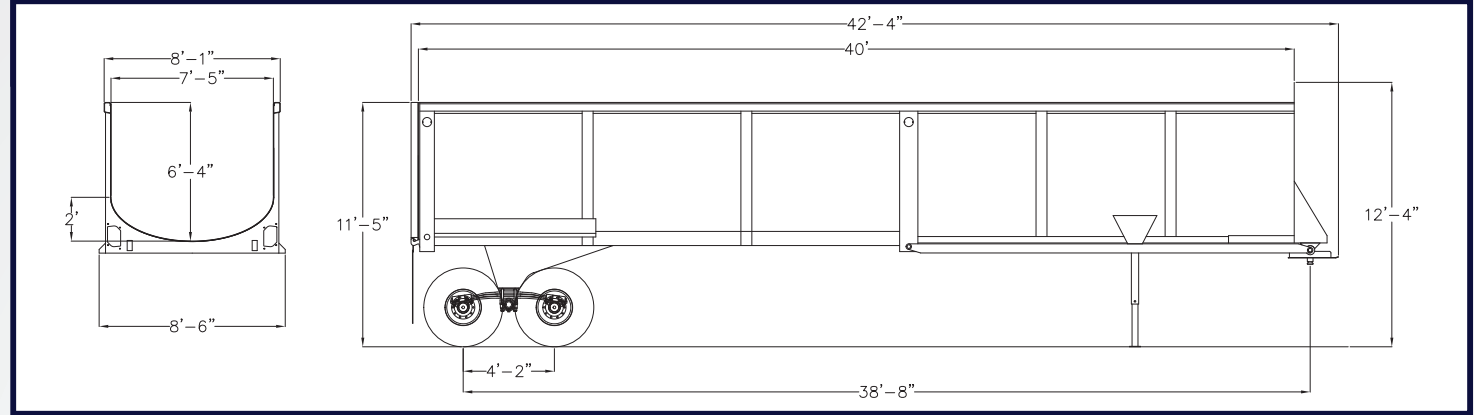

ALL 8 TIRES STAY ON THE GROUND!

Options

- » Air Ride Suspension
- » Triple Axles
- » Quarter Frame
- » Full Frame
- » Front Fenders
- » Numerous Tarp Options
- » Scale and Tire Inflation Systems
- » Air-Operated Side Latch
- » Custom Lengths and Side Heights
- » Tire Carrier
- » Cab Kit
- » Lift Axle
- » Top Hinge Tailgate
- » Dura-Light Hub and Drum
- » Aluminum Wheels
- » And More!

CONSTRUCTION
TRAILER
SPECIALISTS 00